

On the Throughput-Reliability Tradeoff Analysis in Amplify-and-Forward Cooperative Channels

Jun Li, Wen Chen, Cheng Zhao, Xiaoting Yang, and Xinbing Wang

Department of Electronic Engineering,

Shanghai Jiao Tong University,

Shanghai, China. 200240.

Email: {jleesr80, wenchen, solarismaya, wendysagacity, xwang8}@sjtu.edu.cn

Abstract—Cooperative transmission protocols are always designed to reach the largest diversity gain and the largest network capacity simultaneously. The concept of diversity-multiplexing tradeoff (DMT) in MIMO systems put forward by Zheng and Tse has been extended to this field. In fact, many works that follow from this famous rule have been done to achieve more perfect tradeoff curves. However, the concept of multiplexing gain in DMT constrains a better understanding of the asymptotic interplay between transmission rate, frame error probability (FEP) and signal-to-noise ratio (SNR), and also fails to predict FEP curves accurately. Another formulation called the throughput-reliability tradeoff (TRT) was then proposed to avoid such limitation. Under this new rule, Azarian and Gamal well elucidated the asymptotic trends exhibited by the FEP curves in block-fading MIMO channels. Meanwhile they doubted whether the new rule can be used in more general channels and protocols. In this paper, we will prove that it does hold true in amplify-and-forward (AF) cooperative protocols. We propose a symbol based slotted amplify-and-forward (SSAF) protocol as the infrastructure to deduce the relationship between DMT and TRT. Furthermore, we derive the theoretical FEP curves predicted by TRT. We show that the FEP curves by simulation will asymptotically overlap with the theoretical curves predicted by TRT under some circumstance.

I. INTRODUCTION

Recently, there has been a growing interest in the design and analysis of protocols in cooperative transmission systems [1]-[5], [14], [16]-[19]. Such a system can be viewed as a derivative form of MIMO system. As well known, MIMO is generally used for increasing the amount of diversity to combat channel fading or the number of the degrees of freedom [6]-[9]. Under some particularly arrangement, e.g., with clustered and full-duplex relays, cooperative channels can mimic the MIMO channels gratefully [19]. On the other hand, network information theory has been studied for almost 30 years, which focus on the achievable rates and capacity region in various network channels [10]-[14], such as relay channels, broadcast channels and so on. Thus, from a new perspective of combining MIMO with network information theory, the designer of protocols in cooperative transmission systems should pay attention to not only the diversity gain but also the network capacity.

In [15], Zheng and Tse gave an formulation between the diversity gain and multiplexing gain by using the Gaussian code. The same derivation method can be extended to any general code, which is called diversity-multiplexing tradeoff

(DMT). The DMT assumes a family of codes, in which diversity gain d and multiplexing gain r are defined by

$$d \triangleq - \lim_{\rho \rightarrow \infty} \frac{\log(P_e(\rho))}{\log \rho} \quad \text{and} \quad r \triangleq \lim_{\rho \rightarrow \infty} \frac{R(\rho)}{\log \rho}, \quad (1)$$

where ρ , $P_e(\rho)$ and $R(\rho)$ represent the signal-to-noise ratio (SNR), frame error probability (FEP) and transmission rate respectively. So a scheme's DMT means that at the r multiplexing gain, the diversity gain that the scheme acquires should not exceed $d(r)$. More specifically, for a given MIMO system and a fixed coding scheme, if we utilize more antennas to get the diversity gain, the transmitted data rate will be cut down for the limited resources of the channels and vice versa. There must be a tradeoff between diversity gain and multiplexing gain in MIMO systems among various coding schemes. Now, this elegant formulation is successfully used as a standard in cooperative communication systems to evaluate the performance of different cooperative transmission protocols [16]-[19].

However, Azarian and Gamal pointed out the limitation of DMT imposed by the concept of multiplexing gain, that is, it will lead to a malfunction in predicting the FEP curves due to

$$\limsup_{\rho \rightarrow \infty} \frac{R}{\log \rho} \neq \liminf_{\rho \rightarrow \infty} \frac{R}{\log \rho}. \quad (2)$$

Meanwhile, they also put forward a relationship between the three quantities $\{R, \log \rho, P_e(R, \rho)\}$, which is called throughput-reliability tradeoff (TRT) [20]. From the simulations in [20], we can see that TRT predicts the FEP curves accurately, especially when SNR is large enough. In [21], the authors posed the following open problem: "For MIMO channels, we established the correspondence between DMT and TRT formulations. It remains to see if such a correspondence exists for general channels or not". This motivates us to have a in-depth investigation on the correspondence between DMT and TRT formulations in the scenario of cooperative communications.

In this paper, we focus on the amplified-and-forward (AF) protocol, which is very popular in cooperative communications because of the simplicity. In the AF protocol, relays receive the signals from source according to some timing sequence arranged beforehand, then relays amplify these signals straightforward without decoding them and transmit the

amplified signals to destination. There are various derivative form of AF protocol classified by the scheduling strategies. A typical and efficient AF protocol in cooperative communications is slotted amplify-and-forward (SAF) protocol [18]. Another well-known AF protocol is non-orthogonal amplify-and-forward (NAF) protocol [3], [16], which can be seen as a special case of SAF.

To see whether the concept of TRT can be used in AF protocols to reveal the relationship between R , $\log \rho$ and $P_e(R, \rho)$, we should

1) *find out the difference between AF cooperative channels and MIMO channels:* The difference between AF cooperative channels and MIMO channels is that there are hops (relays) between the source and destination in the former while the source and destination are connected directly in the latter. How to deal with these hops in channel's model is important. In this paper, we only consider the AF cooperative channels with one hop scenario, whereas our work can be extended to multi-hop scenarios by Lemma 1.

2) *set up an simple and common AF protocol as infrastructure to easy the analysis:* We propose a symbol based SAF (SSAF) protocol as our infrastructure. In SSAF protocol, relays are isolated from each other, i.e, one relay does not receive the signals from other relays. So there is only one hop between source and destination. SSAF protocol can be seen as a specialized SAF with the round-robin scheduling strategy [18], which can help us easy the process of proof without loss of generality. Note that though we base our main work on SSAF protocol, the result can be extended to any other AF protocols.

3) *exhibit the limitation which is imposed by DMT while is solved by TRT:* We show that under some circumstance in SSAF protocol, DMT rule can not give a prediction on outage probability as well as FEP because of the concept of multiplexing gain. But TRT rule can deal with such problem.

The rest of the paper is organized as follows. In section II, we make a general view on the description of NAF and SAF protocols, and then we propose a symbol based SAF protocol. The channel model is also established. In last part of the section, we give two lemmas which will be used in the sequel. TRT analysis on SSAF is deployed in section III, where we prove the TRT formulation. Section ?? demonstrates the rule though numerical results, which show that besides MIMO systems, the concept of TRT is also holding in cooperative AF protocols.

The notations used in this paper go as follows. $(x)^+$ denotes $\max\{0, x\}$, $(x)^-$ denotes $\min\{0, x\}$, \mathbb{R}^N and \mathbb{C}^N means the set of real and complex N -tuples, and \mathbb{R}^{N+} denotes the set of non-negative N -tuples. If some set $\mathcal{O} \subseteq \mathbb{R}^N$, we denote the complete set of \mathcal{O} as \mathcal{O}^c , while $\mathcal{O} \cap \mathbb{R}^{N+}$ as \mathcal{O}^+ . Λ_x denotes the auto-covariance matrix of vector x .

II. SYSTEM MODEL AND PRELIMINARIES

In this section, we will introduce two cooperative communication models and prove two lemmas that will be used in the next section to establish the TRT analysis.

A. System Model

Without loss of generality, we establish a cooperative channel model which has one source, one destination and N relays. All channels are assumed to be flat Rayleigh-fading and quasi-static in at least one frame period, all nodes are in half-duplex mode, and all noises observed by relays and destination are Gaussian distribution. Furthermore, we use g_i , \bar{h} , h_i and $k_{i,j}$ to denote the channels between source and the i -th relay, source and destination, the i -th relay and destination, the i -th relay and the j -th relay respectively (see Fig. 1). When relays are isolated from each other, the channels coefficients $k_{i,j} = 0$.

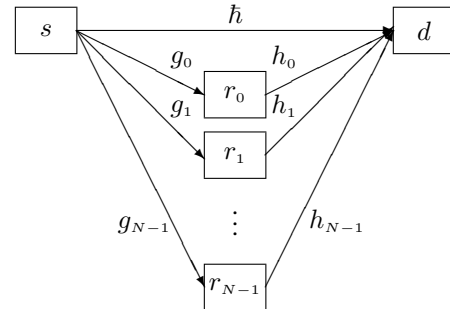

Fig. 1. Cooperative channels with N isolated relays

For the sake of understanding, we give a simple model description of NAF and SAF protocols. For more details, refer to [3], [16], [18]. Note that in Fig. 2 and Fig. 3, dashed boxes mean the receiving procedure while the solid ones mean transmitting.

In an NAF protocol (see Fig. 2), N cooperative frames are concatenated to a superframe, while each cooperative frame x_n can be split into two fragment $x_{0,n}$ and $x_{1,n}$ which will be transmitted in two time slots.

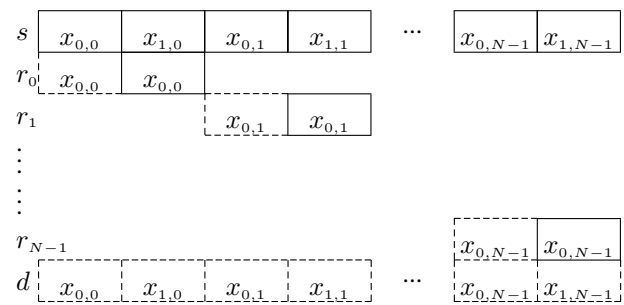

Fig. 2. Frame structure and relaying sequence in NAF protocol

For the SAF protocol (see Fig. 3), the superframe is composed of $N+1$ cooperative frames, and each cooperative frame is transmitted in a time slot by the source.

Obviously, NAF protects half frames by relays, while in SAF, only one frame is out of diversity. In this sense, NAF is suboptimal and can be viewed as a transform of SAF with two time slots.

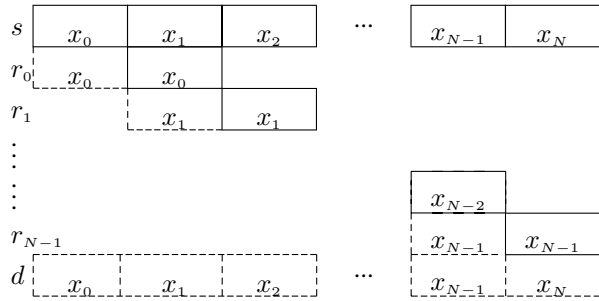

Fig. 3. Frame structure and relaying sequence in SAF protocol

Consider the extreme case where each cooperative frame in SAF only contains one symbol, and the isolated relays are arranged by round-robin scheduling strategy [18], then we get the SSAF naturally. Since symbol is the basic unit of the transmitting data, SSAF get the largest diversity gain as possible. By using relays circularly, SSAF can deal with $l > N$ where l is the frame length. The destination's received signal during a frame will be

$$\mathbf{y} = \mathbf{H} \mathbf{x} + \begin{bmatrix} 0 & \mathbf{O} \\ \mathbf{O} & \Xi \end{bmatrix} \begin{bmatrix} 0 \\ \mathbf{w} \end{bmatrix} + \mathbf{v}, \quad (3)$$

where $\mathbf{y} \in \mathbb{C}^l$ represents the vector of the received symbols at the destination, $\mathbf{x} \in \mathbb{C}^l$ the vector of source signals, $\mathbf{w} \in \mathbb{C}^{l-1}$ the vector of noise samples observed by the relays with the variance σ_w^2 , $\mathbf{v} \in \mathbb{C}^l$ the vector of noise samples observed by the destination with variance σ_v^2 , $\Xi \in \mathbb{C}^{(l-1) \times (l-1)}$, $\mathbf{H} \in \mathbb{C}^{l \times l}$. Specifically,

$$\Xi = \begin{bmatrix} h_0 b_0 & \cdots & 0 & \cdots & 0 \\ \vdots & & \vdots & & \vdots \\ 0 & \cdots & h_{i_N} b_i & \cdots & 0 \\ \vdots & & \vdots & & \vdots \\ 0 & \cdots & 0 & \cdots & h_{(l-2)_N} b_{l-2} \end{bmatrix},$$

$$\mathbf{H} = \begin{bmatrix} \bar{h} & 0 & \cdots & 0 & 0 & \cdots & 0 & 0 \\ g_0 h_0 b_0 & \bar{h} & \cdots & 0 & 0 & \cdots & 0 & 0 \\ \vdots & \vdots & & \vdots & \vdots & & \vdots & \vdots \\ 0 & 0 & \cdots & \bar{h} & 0 & \cdots & 0 & 0 \\ 0 & 0 & \cdots & g_{i_N} h_{i_N} b_i & \bar{h} & \cdots & 0 & 0 \\ \vdots & \vdots & & \vdots & \vdots & & \vdots & \vdots \\ 0 & 0 & \cdots & 0 & 0 & \cdots & \bar{h} & 0 \\ 0 & 0 & \cdots & 0 & 0 & \cdots & g_{(l-2)_N} h_{(l-2)_N} b_{l-2} & \bar{h} \end{bmatrix},$$

where the subscript i_N means $(i \bmod N)$, and b_i ($b_i \leq \sqrt{E/(|g_{i_N}|^2 E + \sigma_w^2)}$) represents the repetition gain of the i -th symbol at the relay i_N .

B. Preliminaries

In the sequel, we will summarize several expressions and results that may be used latter. We denote that as $\rho \rightarrow \infty$, $f(\rho) \doteq \rho^\alpha$ if function $f(\rho)$ is exponentially equal to ρ^α , and $f(\rho) \stackrel{\circ}{=} q(\rho)$ if $f(\rho)$ is linearly equal to $q(\rho)$, that is

respectively,

$$\lim_{\rho \rightarrow \infty} \frac{\log f(\rho)}{\log \rho} = \alpha \quad \text{and} \quad \lim_{\rho \rightarrow \infty} f(\rho) = \lim_{\rho \rightarrow \infty} q(\rho) + \log b. \quad (4)$$

The coefficient $k_{i,j}$ of Rayleigh-fading channel between nodes i and j is Gaussian random variable. Suppose that the probability density function (PDF) of $|k_{i,j}|^2$ is $\exp(-|k_{i,j}|^2)$. Then we introduce another variable

$$\eta_{i,j} = \frac{\log(1 + \rho |k_{i,j}|^2)}{R}. \quad (5)$$

Thus, the PDF of $\eta_{i,j}$ can be expressed as

$$p(\eta_{i,j}) = \frac{K}{\rho} \exp\left(-\frac{2^{\eta_{i,j} R} - 1}{\rho}\right) 2^{\eta_{i,j} R}, \quad (6)$$

where $K = R \ln 2$ is a constant to $\eta_{i,j}$.

In N -relay systems, relays can be organized as arbitrary topological types. One extreme situation is that all relays are serialized as N hops between source and destination.

III. THROUGHPUT-RELIABILITY TRADEOFF ANALYSIS OF SSAF PROTOCOL

In non-ergodic fading channels, performance of the connection is evaluated in terms of outage probability, which is defined as the event that the instantaneous mutual information does not support the intended rate [22], [23], i.e.,

$$\mathcal{O}_p \triangleq \{\mathbf{H} | I(x; y | \mathbf{H} = \mathbf{H}) < R\}, \quad (7)$$

where \mathbf{H} is a channel realization. The lower bound of \mathcal{O}_p 's probability is defined as outage probability $P_o(R, \rho)$ [22], [23]. Therefore,

$$P_o(R, \rho) = \inf_{\Lambda_x} \Pr\{\mathcal{O}_p\} = \Pr\left\{\max_{\Lambda_x} I(x; y | \mathbf{H}) < R\right\}. \quad (8)$$

The asymptotic relationship of R , ρ and $P_o(R, \rho)$ has been well derived in MIMO channels [20], [21]. Our work proves that such relationship also holds in SSAF protocol.

Theorem 1: For the one source, one destination and N relays SSAF block-fading cooperative channels with l ($l \geq N + 1$) symbols perframe, there are k ($N \geq k \geq 0$, $k \in \mathbb{Z}$) operating regions, in which

$$\lim_{\substack{\rho \rightarrow \infty \\ (R, \rho) \in \mathcal{R}(k)}} \frac{\log P_o(R, \rho) - c(k)R}{\log \rho} = -g(k), \quad (9)$$

where $\mathcal{R}(k)$ means the k -th operating region, $g(k)$ is referred to the reliability gain coefficient and $\frac{g(k)}{c(k)}$ is referred to the throughput gain coefficient.

Consider two cases, $(l-1)_N = 0$ and $(l-1)_N \neq 0$.

1) $(l-1)_N = 0$: The k regions can be combined to two super operating regions, i.e.,

$$\mathcal{R}(k) \triangleq \begin{cases} \left\{ (R, \rho) \mid \frac{(l-1)(k+1)}{lN} > \frac{R}{\log \rho} > \frac{(l-1)k}{lN} \right\}, & N > k \geq 0, \\ \left\{ (R, \rho) \mid 1 > \frac{R}{\log \rho} > \frac{l-1}{l} \right\}, & k = N, \end{cases} \quad (10)$$

and $\{c(k), g(k)\}$ are defined according to $\mathcal{R}(k)$,

$$\{c(k), g(k)\} \triangleq \begin{cases} \left\{ 1 + \frac{lN}{l-1}, 1 + N \right\}, & N > k \geq 0, \\ \{1, 1\}, & k = N. \end{cases} \quad (11)$$

2) $(l-1)_N = m$ ($0 < m < N$): There are two extreme cases, i.e., the remaining m symbols are transferred through the best m relay channels and the worst m relay channels. They give the two bounds of the outage probability curves. When the best m relay channels are first used (BCFU), there are three super regions:

$$\mathcal{R}_1(k) \triangleq \begin{cases} \left\{ (R, \rho) \mid \frac{(l-1+N-m)(k+1)}{lN} > \frac{R}{\log \rho} > \frac{(l-1+N-m)k}{lN} \right\}, & m > k \geq 0, \\ \left\{ (R, \rho) \mid \frac{(l-1-m)(k+1)+mN}{lN} > \frac{R}{\log \rho} > \frac{(l-1-m)k+mN}{lN} \right\}, & N > k \geq m, \\ \left\{ (R, \rho) \mid 1 > \frac{R}{\log \rho} > \frac{l-1}{l} \right\}, & k = N, \end{cases} \quad (12)$$

and $\{c_1(k), g_1(k)\}$ are defined according to $\mathcal{R}_1(k)$, that is,

$$\{c_1(k), g_1(k)\} \triangleq \begin{cases} \left\{ 1 + \frac{lN}{l-1+N-m}, 1 + N \right\}, & m > k \geq 0, \\ \left\{ 1 + \frac{lN}{l-1-m}, 1 + \frac{(l-1)N}{l-1-m} \right\}, & N > k \geq m, \\ \{1, 1\}, & k = N. \end{cases} \quad (13)$$

When the worst m channels are first used (WCFU), then

$$\mathcal{R}_2(k) \triangleq \begin{cases} \left\{ (R, \rho) \mid \frac{(l-1-m)(k+1)}{lN} > \frac{R}{\log \rho} > \frac{(l-1-m)k}{lN} \right\}, & N - m > k \geq 0, \\ \left\{ (R, \rho) \mid \frac{(l-1+N-m)(k+1)+mN-N^2}{lN} > \frac{R}{\log \rho} > \frac{(l-1+N-m)k+mN-N^2}{lN} \right\}, & N > k \geq N - m, \\ \left\{ (R, \rho) \mid 1 > \frac{R}{\log \rho} > \frac{l-1}{l} \right\}, & k = N, \end{cases} \quad (14)$$

and $\{c_2(k), g_2(k)\}$ are defined according to $\mathcal{R}_2(k)$, that is,

$$\{c_2(k), g_2(k)\} \triangleq \begin{cases} \left\{ 1 + \frac{lN}{l-1-m}, 1 + N \right\}, & N - m > k \geq 0, \\ \left\{ 1 + \frac{lN}{l-1+N-m}, 1 + \frac{(l-1)N}{l-1+N-m} \right\}, & N > k \geq N - m, \\ \{1, 1\}, & k = N. \end{cases} \quad (15)$$

Now we investigate the relationship between TRT and DMT in SSAF protocol. In [18], the DMT of isolated relays by dumb scheduling method achieve the DMT by

$$d(r) = (1-r)^+ + N \left(1 - \frac{M}{M-1} r \right)^+, \quad (16)$$

where M is the number of frames in a cooperative super frame. Then in SSAF by letting $M = l$, we get

$$d(r) = (1-r)^+ + N \left(1 - \frac{l}{l-1} r \right)^+. \quad (17)$$

It is evident that the larger the l is, the more diversity gain can be acquired. The DMT formulation proves that SSAF protocol can get the largest diversity gain. So the frame length l is chosen to approach the maximum of $d(r)$ as long as the channels permit.

Moreover, we notice that the DMT given by (17) only considers the case $(l-1)_N = 0$. Without the concept of operating region and constrained by the concept of multiplexing gain, it is very difficult to explore the case $(l-1)_N \neq 0$ more comprehensively by using the DMT. A feasible way is to work out the optimized solution by appealing to the linear programming method.

From the DMT curve of SSAF protocol, we can see that the curve is not continuous in the first order differential coefficient, i.e., there are inflexions at the curve. In fact, these inflexions split the DMT curve into segments which correspond to the super operating regions in TRT since the following observation in [20] also come into existence,

$$\begin{aligned} g(k) &= d(k) - kd'(k) \\ c(k) &= -d'(k). \end{aligned} \quad (18)$$

On the other hand, Zheng and Tse have proved that when ρ approaches to infinity, $P_o(R, \rho)$ will be equal to the $P_e(R, \rho)$ [15] in MIMO systems. With the same lines, we can prove the following theorem,

Theorem 2: The FEP $P_e(R, \rho)$ of the SSAF protocols with l ($l \geq N + 1$) symbols perframe satisfies

$$\lim_{\rho \rightarrow \infty} \frac{\log P_e(R, \rho) - c(k)R}{\log \rho} = -g(k), \quad (19)$$

where $\mathcal{R}(k)$, $c(k)$ and $g(k)$ are given by (16) ~ (19).

We get the proof by following that of *Theorem 2* in [15].

IV. CONCLUSION

We base our work on the Azarian and Gamal's elegant formulation concluded from MIMO systems to throw a light on the asymptotic interplay between R , $\log \rho$ and $P_e(R, \rho)$ in AF protocols. To do this, we first find out the difference between AF cooperative channels and MIMO channels, i.e., in AF cooperative channels there are at least one hop between source and destination while in MIMO channels the source and destination are directly connected. *Lemma 1* gives the expressions of mutual information between source and destination with multi-hop in AF cooperative channels, which facilitates us to deduce the TRT formulation in AF protocols. Then we propose a common AF protocol to ease our work. We study the typical and efficient SAF protocol and propose the symbol based SAF (SSAF) protocol as our infrastructure. SSAF protocol is a common AF protocol with one hop between source and destination, which can achieve more diversity gain than any other AF protocols since only one symbol out of a transmitted frame lost the protect by relays. At last we deduce the TRT formulation on the established SSAF channel model to reveal the relationship between R , $\log \rho$, $P_o(R, \rho)$ and $P_e(R, \rho)$. We predict that the same deduction method can be used in other one hop and multi-hop AF protocols with different DMT since *Lemma 1* has given the mutual information between source and destination with multi-hop in AF protocols. In numerical results, we prove that $P_e(R, \rho)$ can approach $P_o(R, \rho)$ under some circumstance. Besides R and $\log \rho$, we emphasize that the frame length l is also an important factor that impacts on the $P_e(R, \rho)$ and $P_o(R, \rho)$. Simulations valid our deduction on the condition that when SNR is large enough and operating point is well within certain operating region. The analytical methods have been proved to be suited to the AF protocols.

ACKNOWLEDGMENT

This work is supported by NSF China #60672067, #60702046, by NSF Shanghai #06ZR14041, by Shanghai-Canada NRC #06SN07112, by Cultivation Fund of the Key Scientific and Technical Innovation Project, Ministry of Education of China #706022, by Program for New Century Excellent Talents in University #NCET-06-0386, and by PUJIANG Talents #07PJ4046.

REFERENCES

- [1] J. N. Laneman and G. W. Wornell, "Distributed space-time-coded protocols for exploiting cooperative diversity in wireless networks," *IEEE Trans. Inf. Theory*, vol. 49, no. 10, pp. 2415-2425, Oct. 2003.
- [2] J. N. Laneman, D. N. C. Tse, and G. W. Wornell, "Cooperative diversity in wireless networks: Efficient protocols and outage behavior," *IEEE Trans. Inf. Theory*, vol. 51, no. 12, pp. 3062-3080, Dec. 2004.
- [3] R. U. Nabar, F. W. Kneubuhler, and H. Bölcskei, "Performance limits of amplify-and-forward based fading relay channels," *Proc. IEEE Int. Conf. Acoustics, Speech and Signal Processing*, vol. 4, Montreal, QC, Canada, May 2004, pp. 565-568.
- [4] R. U. Nabar, H. Bölcskei, and F. W. Kneubuhler, "Fading relay channels: Performance limits and space-time signal design," *IEEE J. Sel. Areas Commun.*, vol. 22, no. 6, pp. 1099-1109, Aug. 2004.
- [5] M. Janani, A. Hedayat, T. Hunter, and A. Nosratinia, "Coded cooperation in wireless communications: Space-time transmission and iterative decoding," *IEEE Trans. Signal Process.*, vol. 52, no. 2, pp. 362-371, Feb. 2004.
- [6] S. Alamouti, "A simple transmitter diversity scheme for wireless communications," *IEEE J. Sel. Area Commun.*, vol. 16, no. 8, pp. 1451-1458, Oct. 1998.
- [7] G. Foschini, G. Golden, R. Valenzuela, and P. Wolniansky, "Simplified processing for high spectral efficiency wireless communication employing multi-element arrays," *IEEE J. Sel. Area Commun.*, vol. 17, no. 11, pp. 1841-1852, Nov. 1999.
- [8] V. Tarokh, H. Jafarkhani, and A. R. Calderbank, "Space-time codes for high data rate wireless communication: Performance criterion and code construction," *IEEE Trans. Inf. Theory*, vol. 44, no. 2, pp. 744-765, Mar. 1998.
- [9] V. Tarokh, H. Jafarkhani, and A. R. Calderbank, "Space-time block code from orthogonal designs," *IEEE Trans. Inf. Theory*, vol. 45, no. 4, pp. 1456-1467, Sep. 1999.
- [10] T. M. Cover and A. A. El-Gamal, "Capacity theorems for the relay channel," *IEEE Trans. Inf. Theory*, vol. 25, no. 5, pp. 572-584, Sep. 1979.
- [11] T. M. Cover and G. S. L. Leung, "An achievable rate region for the multiple-access channel with feedback," *IEEE Trans. Inf. Theory*, vol. 27, no. 3, pp. 292-298, May. 1981.
- [12] L. H. Ozarow, "The capacity of the white gaussian multiple access channel with feedback," *IEEE Trans. Inf. Theory*, vol. 30, no. 4, pp. 623-629, Jul. 1984.
- [13] T. M. Cover, "Comments on broadcast channels," *IEEE Trans. Inf. Theory*, vol. 44, no. 6, pp. 2524-2530, Oct. 1998.
- [14] G. Kramer, M. Gastpar, and P. Gupta, "Cooperative strategies and capacity theorems for relay networks," *IEEE Trans. Inf. Theory*, vol. 51, no. 9, pp. 3037-3063, Sep. 2005.
- [15] L. Zheng and D. N. C. Tse, "Diversity and multiplexing: A fundamental tradeoff in multiple antenna channels," *IEEE Trans. Inf. Theory*, vol. 49, no. 5, pp. 1073-1096, May 2003.
- [16] K. Azarian, H. El-Gamal, and P. Schniter, "On the achievable diversity-multiplexing tradeoff in half-duplexing cooperative channels," *IEEE Trans. Inf. Theory*, vol. 51, no. 12, pp. 4152-4172, Dec. 2005.
- [17] S. Yang and J.-C. Belfiore, "Optimal space-time codes for the MIMO amplify-and-forward cooperative channel," *IEEE Trans. Inf. Theory*, vol. 53, no. 2, pp. 647-663, Feb. 2007.
- [18] S. Yang and J.-C. Belfiore, "Towards the optimal amplify-and-forward cooperative diversity scheme," *submitted to IEEE Trans. Inf. Theory*, Mar. 2006.
- [19] M. Yuksel and E. Erkip, "Cooperative wireless systems: A diversity-multiplexing tradeoff perspective," *submitted to IEEE Trans. Inf. Theory*, Sep. 2006.
- [20] K. Azarian, H. El-Gamal, "The throughput-reliability tradeoff in block-fading MIMO channels," *IEEE Trans. Inf. Theory*, vol. 53, no. 2, pp. 488-501, Feb. 2007.
- [21] K. Azarian, "Outage limited cooperative channels: Protocols and analysis," Ph.D. dissertation, Ohio State Univ., Columbus, OH, 2006.
- [22] L. Ozarow, S. Shamai, and A. Wyner, "Information-theoretic considerations in cellular mobile radio," *IEEE Trans. Veh. Technol.*, vol. 43, no. 3, pp. 359-378, May 1994.
- [23] I. E. Telatar, "Capacity of multi-antenna Gaussian channels," *Europ. Trans. Telecommun.*, vol. 10, pp. 585-595, Nov./Dec. 1999.
- [24] X. Zhang, *Matrix Analysis and Applications*, Bei Jing: Tsinghua Univ., 2004.
- [25] R. A. Horn and C. R. Johnson, *Matrix Analysis*, New York: Cambridge, 1985.